

# Power Delivery Systems

In an era defined by technological developments and rapid digitalisation, having access to power is of unprecedented importance. Without power, we would have no choice but to pull the plug on our tech-centric lifestyles and radically rethink how we approach everything from leisure, retail and entertainment through to education, medicine and more.

Increasingly, though, the ways in which power is delivered into our homes, offices and public spaces must offer the levels of flexibility and accessibility required to enable us to keep pace with the competitive, highly-changeable nature of our world. Power delivery systems are needed to facilitate the use of a wide and growing array of technologies to make it possible for businesses to create spaces that are capable of supporting their commercial objectives and acting as catalysts for success.

Our range of power delivery systems has been created in direct response to these challenges. Engineered to offer unbeatable levels of flexibility and functionality whilst enhancing the aesthetic of interior design schemes, our power delivery systems are ready to take your business from today, into tomorrow and beyond.





Our power delivery systems can be specified for new merchandising systems and displays or retrofitted into existing equipment to ensure you are able to access the solution that is best suited to help your business achieve its goals.



# Power Delivery Systems

## Kontakt

Kontakt is our ultra-flexible shelving system with integrated LED luminaires. It delivers sleek, energy-efficient illumination to ensure that product displays are presented as effectively as possible.

With no wires or connectors, the Kontakt shelving system can be reconfigured quickly and easily to enable brands to update retail environments alongside changing trends and seasonal promotions.

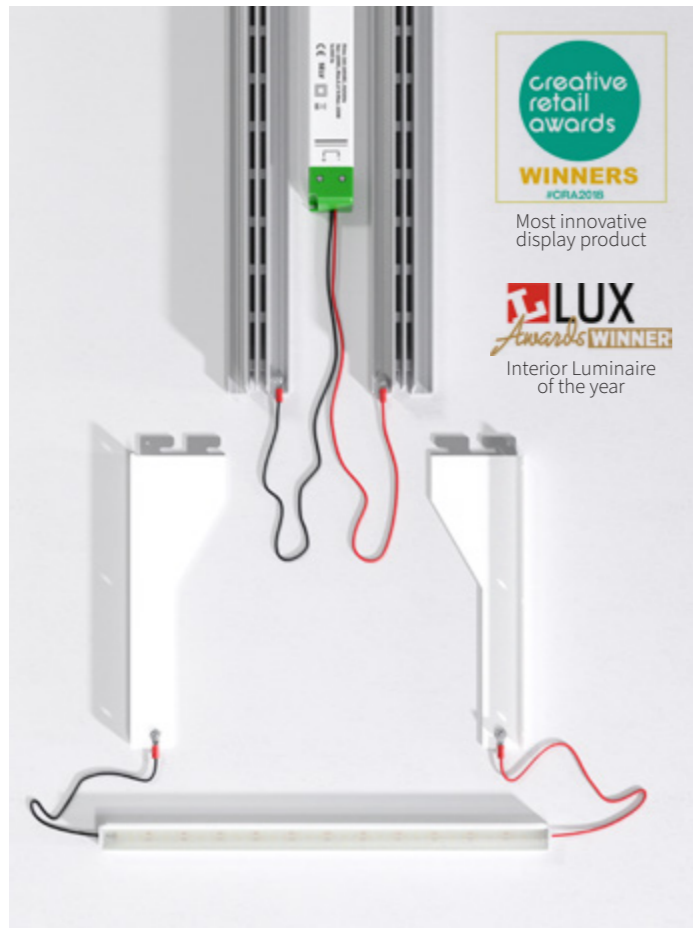

Track Rated Current	Track Mounting Method	Connection Method	Connector Colours	Voltage
16A	Recessed	Wireless	Custom	24v

## Konnekt S50

Konnekt S50 is our power delivery system that is designed to integrate directly into the standard S50 slot details found in many mass-produced retail racking systems.

Konnekt S50 has been developed to work in tandem with 0.9mm back panels without interference and engineered to provide an ultra-flexible solution that is quick and easy to retrofit into retail spaces of all types.



Track Rated Current	Track Mounting Method	Connection Method	Connector Colours	Voltage
6amp	Encapsulated (Steel Upright - S50 Slots)	Magnetic	Black White	12v 24v

## Konnekt Hive

Konnekt Hive is our low voltage power delivery system that provides an accessible, user-friendly way of incorporating electrical accessories into shelving displays.

Engineered to operate using magnets, Konnekt Hive can be fixed directly onto suitable surfaces without the need for complex wiring. It enables users to install and reconfigure display systems with speed and ease and is compatible with a wide range of accessories and LED luminaires.



Track Rating	Track Mounting Method	Connection Method	Connector Colours	Voltage
8AMP	Magnetic	Magnetic	Black/White	12v 24v

## Konnekt Twist

Konnekt Twist is our low voltage power delivery system that provides a flexible, reliable way of including electrical enhancements into shelving displays.

Engineered to operate with ultra-secure twist-lock connection mechanisms, Konnekt Twist is ideal for installing rebated and surface-mounted power tracks discreetly into shelving systems that can then be used to power a wide range of accessories and LED luminaires.



Track Rating	Track Mounting Method	Connection Method	Connector Colours	Voltage
10AMP	Various	Rotary	Black/White	12v 24v

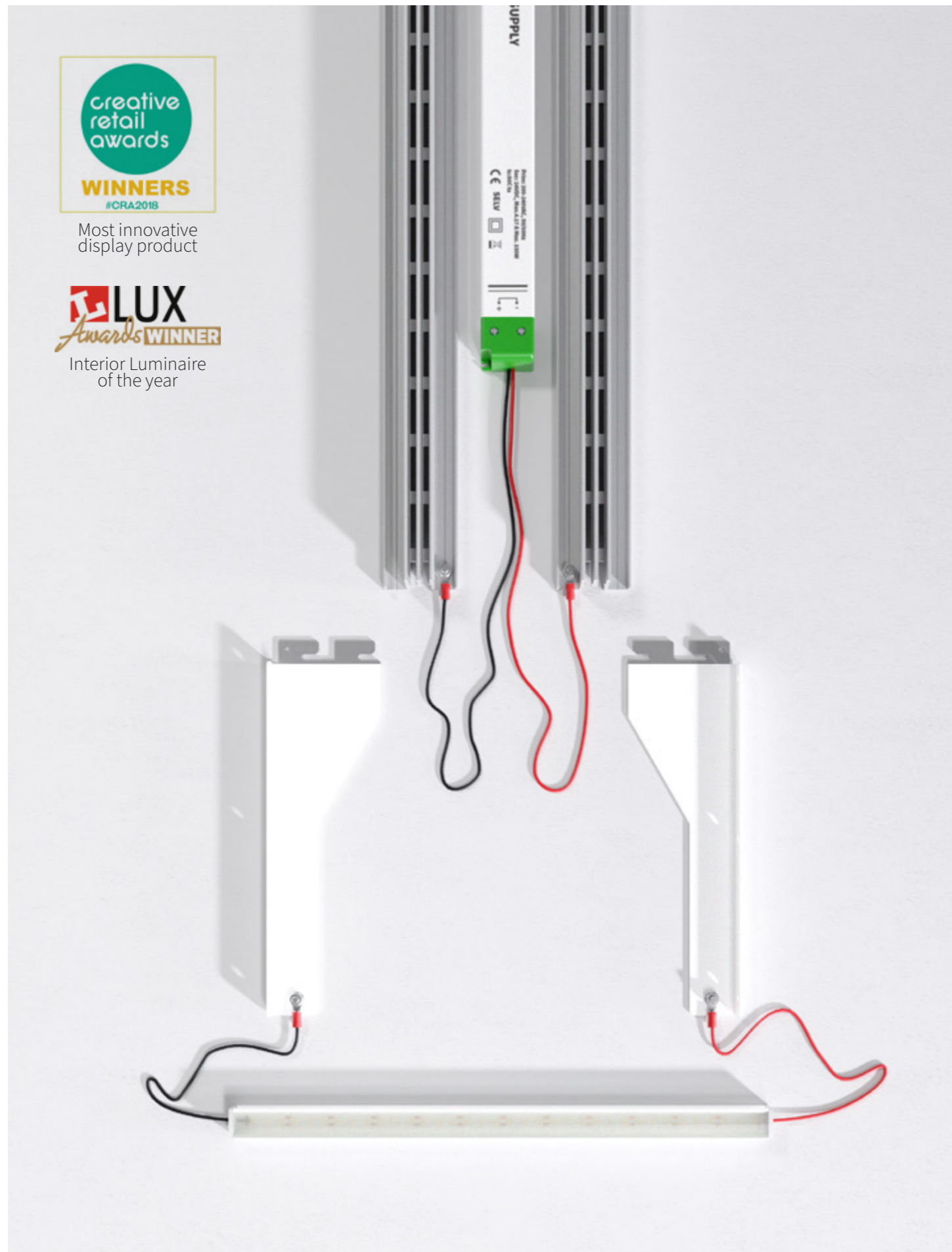

Most innovative display product



Interior Luminaire of the year

# Kontakt

Kontakt is a cable-free shelving system with integrated illumination that exists to provide a user-friendly, ultra-effective way of creating product displays that are guaranteed to make an impact.

Designed with functionality and flexibility at the fore, Kontakt enables the creation of merchandising systems that can be reconfigured to suit different store layouts and customised to suit brand-specific design briefs. LED luminaires switch on automatically when shelves are placed in position on supporting brackets, making for speedy installations and updates.

Kontakt is supplied as a kit of parts to allow for easy on-site installation and is available in a range of different colours, finishes, sizes and LED options.

## Why specify Kontakt

### Cost-effective distribution

Kontakt was developed so that it could be manufactured and delivered as a flat-pack kit of parts to be assembled on site to ensure easy, inexpensive installation, cost-effective distribution and negate issues arising from awkward access points.

### Flawless illumination

We are experts when it comes to LED technology and our team have developed luminaires that use the highest quality LEDs that offer the perfect level of diffusion to evenly illuminate products and diminish shadows.

### Drive sales & focus consumer attention

It's well known fact that illuminated products sell better. We ensure we use LEDs with a high CRI, so that products are literally shown in the best light to allow the merchandise to sing and attract attention.

### Change up the display quickly and easily

Product displays need to be flexible in order to keep up with seasonal and promotional campaigns. Kontakt was designed to make it easy for shop staff to quickly reposition the shelves, without the need to physically disconnect the luminaires.

### Fast turnaround

The Unibox factory is UK based and operates utilising advanced CNC manufacturing technology, giving us the capacity to produce high volumes for roll-out projects within incredibly fast lead times.

### Customised or Bespoke

Whilst the core technology remains the same, we recognise that our customers want to create unique displays that emulate their brands DNA seamlessly. Kontakt allows you to do this by either specifying our standard systems in custom finishes or by working with our product development team to design something bespoke. Either way we have a large range of finishes available to compliment any scheme.

## Key Features



Cable-free technology



Perfect illumination



Custom design service



Cost-effective installation



Quick turnaround times



Suitable for heavy loads (up to 25kg)



Variety of finish options



## Track details

The track can be mounted in a variety of ways to suit your retail designs and manufacturing methods.

Our track has a 32mm pitch which allows for virtually infinite shelf adjustment.

Rated Voltage	Rated Current (Track)	Rated Current (Brackets)	Track
24V	16AMPS	6AMPS	Class III

### Single track

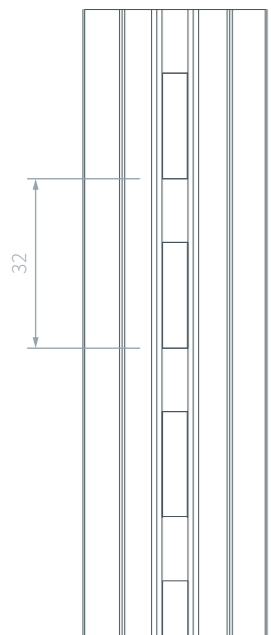
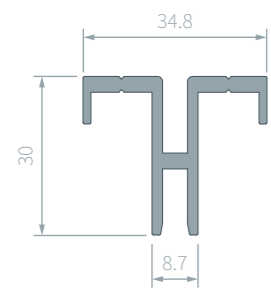

### Double track

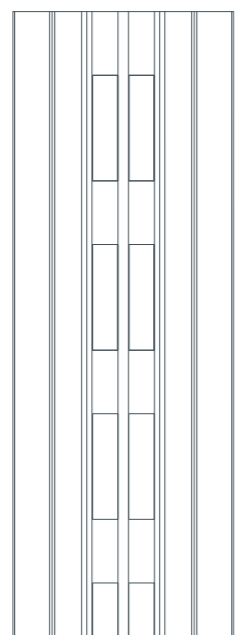
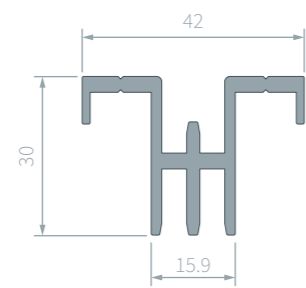

### End bay track

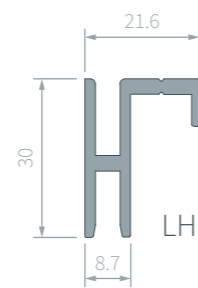

# Konnekt S50

## Why specify Konnekt S50

Konnekt S50 is engineered to enable users to retrofit power supplies directly into compatible shelving systems without the need for modifications or replacements. Built to be a plug-and-play solution, Konnekt S50 slides into the slotted uprights within shelves and holds itself securely in place without the need for tools or specialist installers.

With Konnekt S50, there is no need to de-merchandise shelves when installing luminaires, meaning it is both a time-saving and cost-effective solution for retailers of all types.

Patented connectors guarantee solid, secure connections every time and remove the need for fiddly, unreliable installations. Thanks to its push-fit design, Konnekt S50 guides itself into position before using magnets to lock firmly in place.

Konnekt S50 makes it easy to remove, reposition and reuse power tracks and accessories to provide a future-proof solution that enables users to update the appearance and layout of stores whenever necessary.

## Key features



Custom design service



Cost-effective installation



Quick turnaround times



Reconfigurable



Compatible with international racking system



Variety of finish options



Magnetic connections



## Track details

The track can be mounted in a range of standard steel box sections. Based around standard S50 Racking systems.

Power track is slid into the box section for hidden power connections.

Rated Voltage	Rated Current (Track)	Rated Current (Connectors)
12/24V	6AMP	6AMP

**Compatible slot detail**

**Compatible box sections**  
Mild steel

**Konnekt power track assemblies**

**Compatible Konnektors**

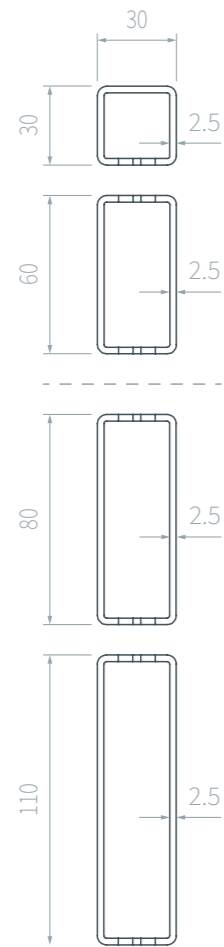
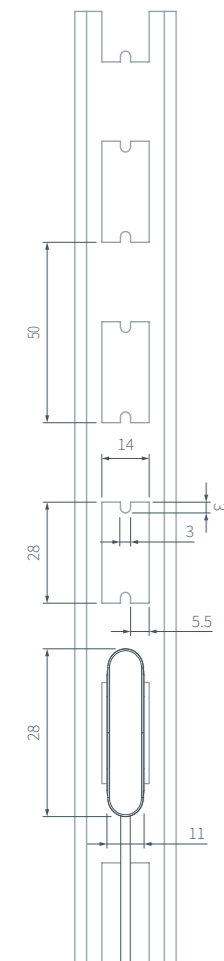

KON-PT-30x30



KON-PT-30x60



KON-PT-30x80



KON-PT-30x110



KON-PF-K2

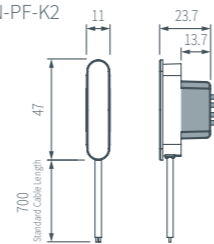

KON-PF-K1

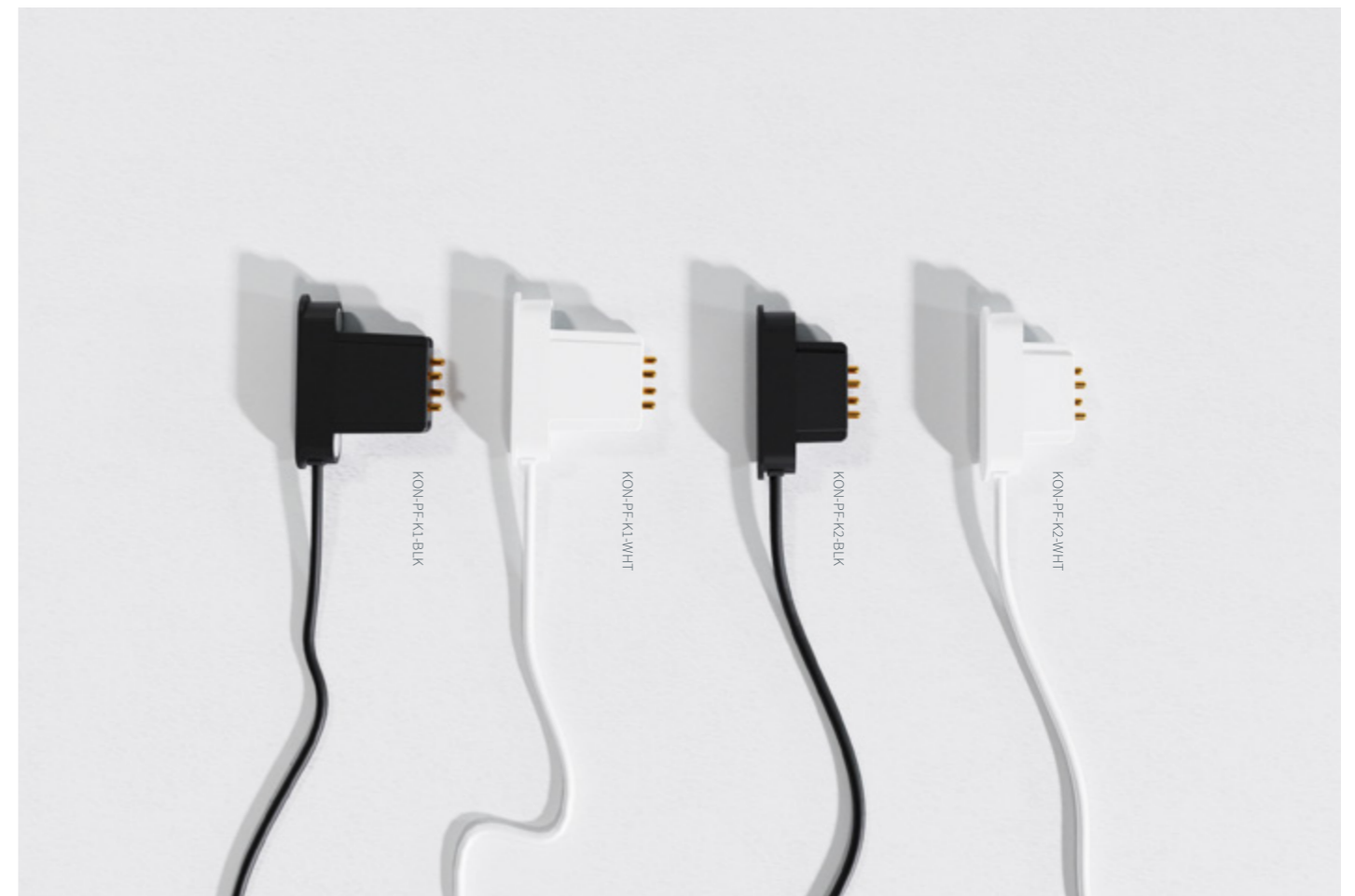
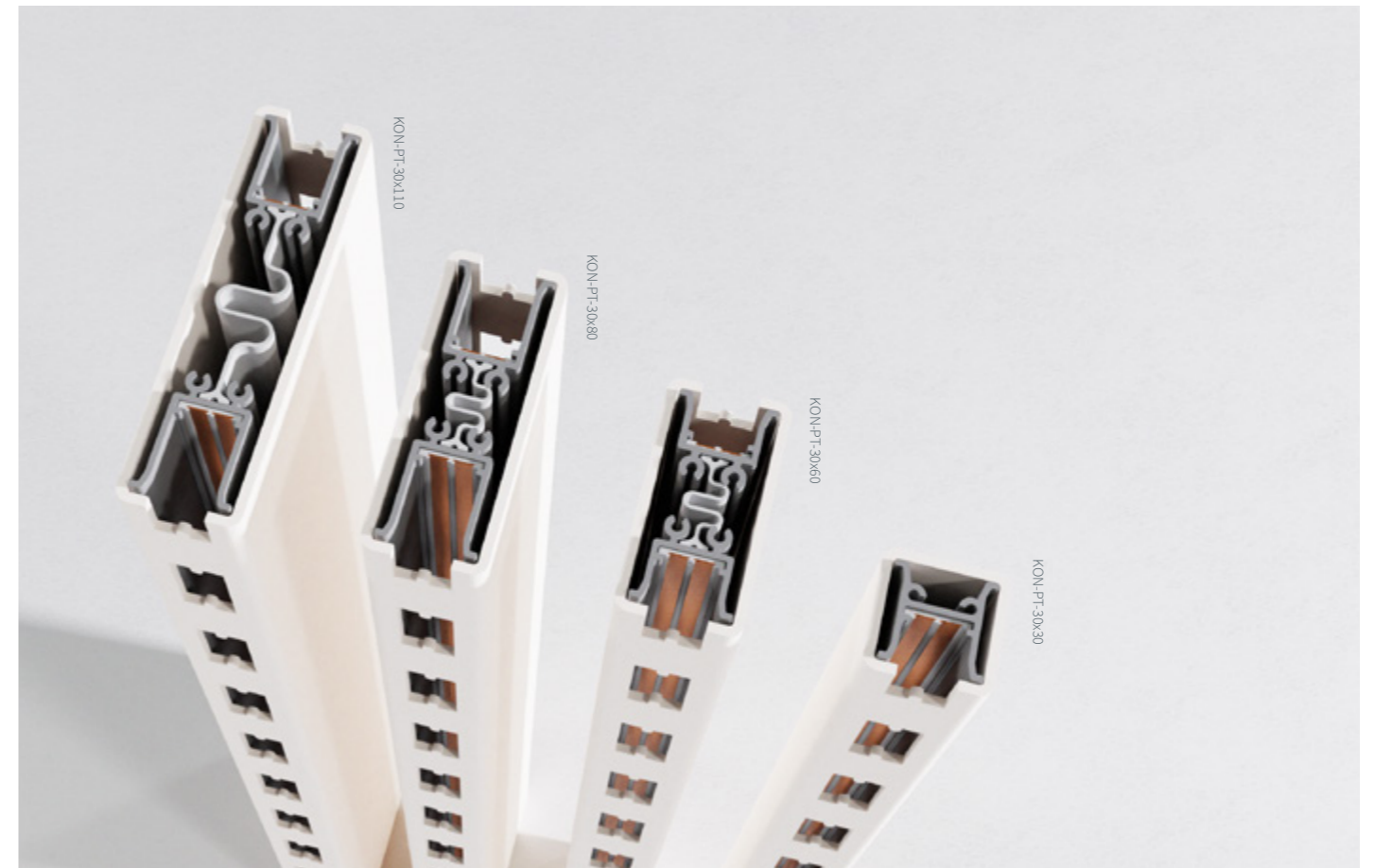
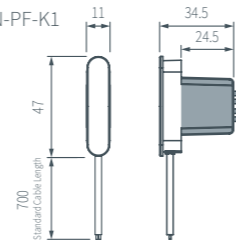





# Konnekt Hive

## Why specify Konnekt Hive

Konnekt Hive provides a low-voltage way of discreetly delivering power into shelving systems and product displays. Konnekt Hive is engineered to operate using powerful neodymium magnets instead of wires, cables and connectors to create a solution that can be fixed directly onto suitable surfaces, thereby enabling users to install and reconfigure their displays with speed and ease.

## Key features



Custom design service



Cost-effective installation



Quick turnaround times



Reconfigurable



Retro Fit



Magnetic Track / connections



## Track details

Konnekt Hive features a slim-line power track with an 8-amp rating, which attaches magnetically to suitable surfaces such as steel back panels, sections, and support brackets.

Rated Voltage	Rated Current (Track)	Rated Current (Connector Power Feed) HV-PF	Rated Current (Connector Take off) HV-PTO	Max Continuous Track Length (mm)
12/24V	8AMP	8AMP	2AMP	1500

**Hive power track - HV-PT**  
Available in black and white

**Hive power track cover - HV-PCVR**  
Available in black and white

**Hive power feed - HV-PF**  
Available in black and white

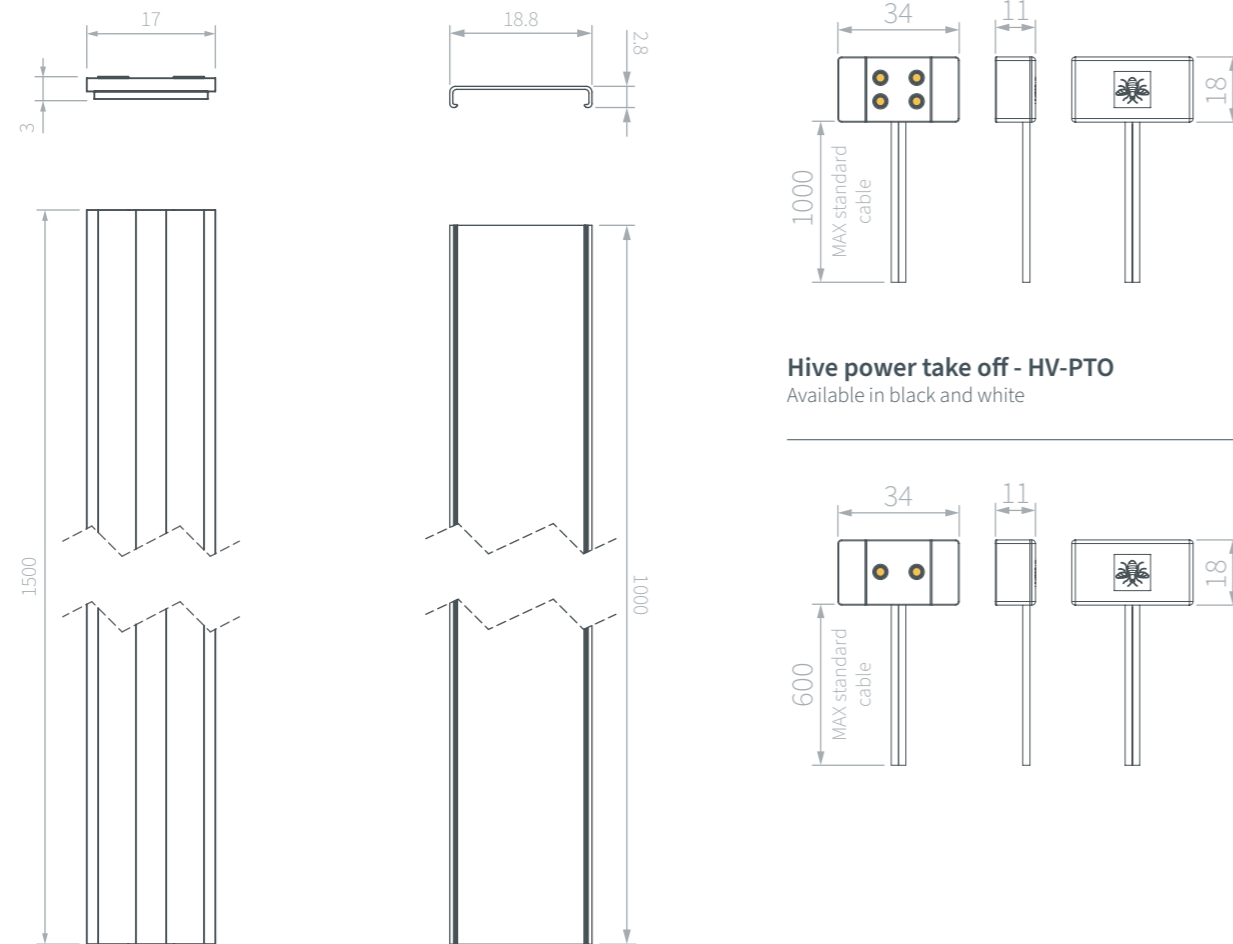

**Hive power take off - HV-PTO**  
Available in black and white

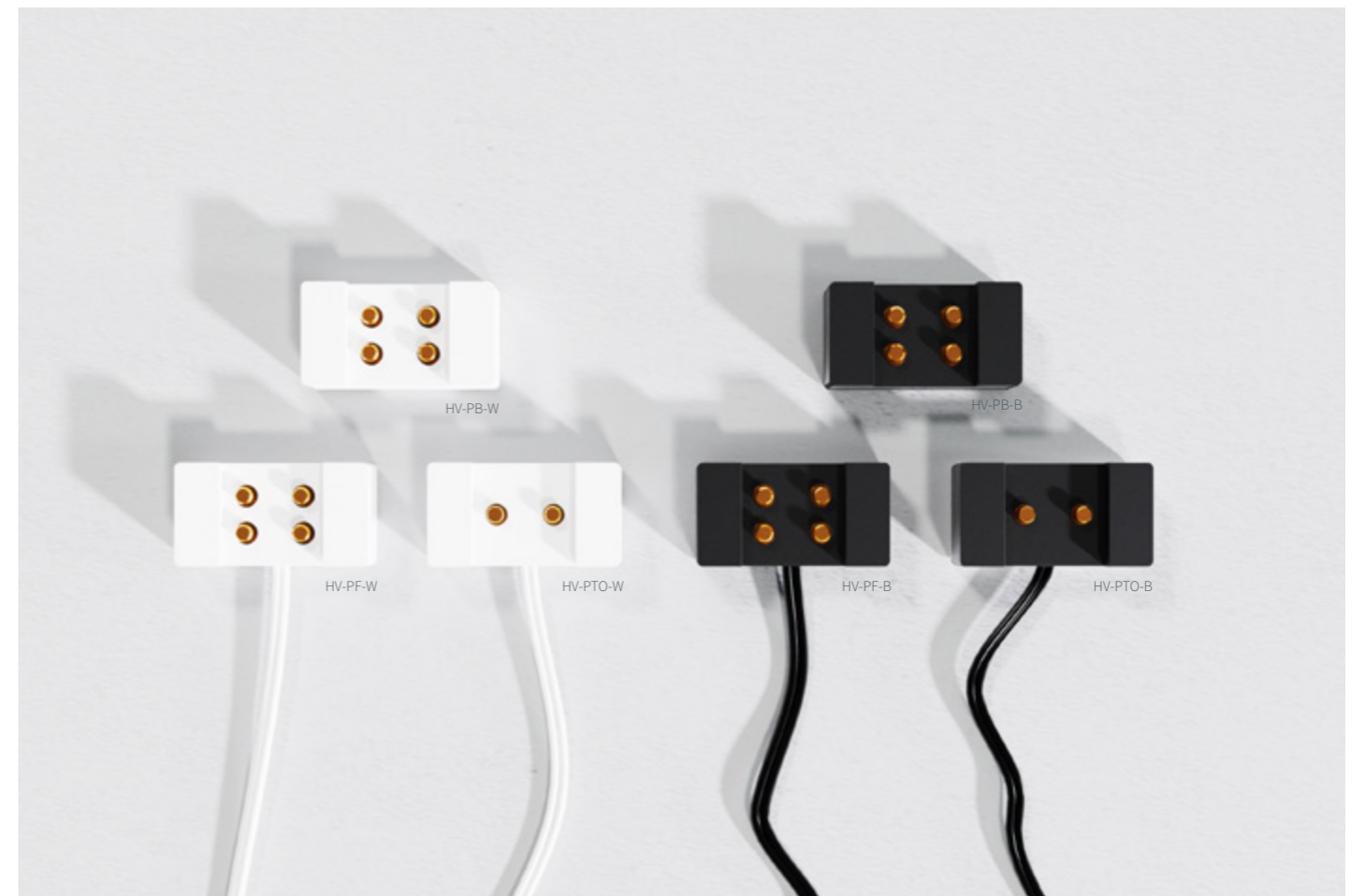
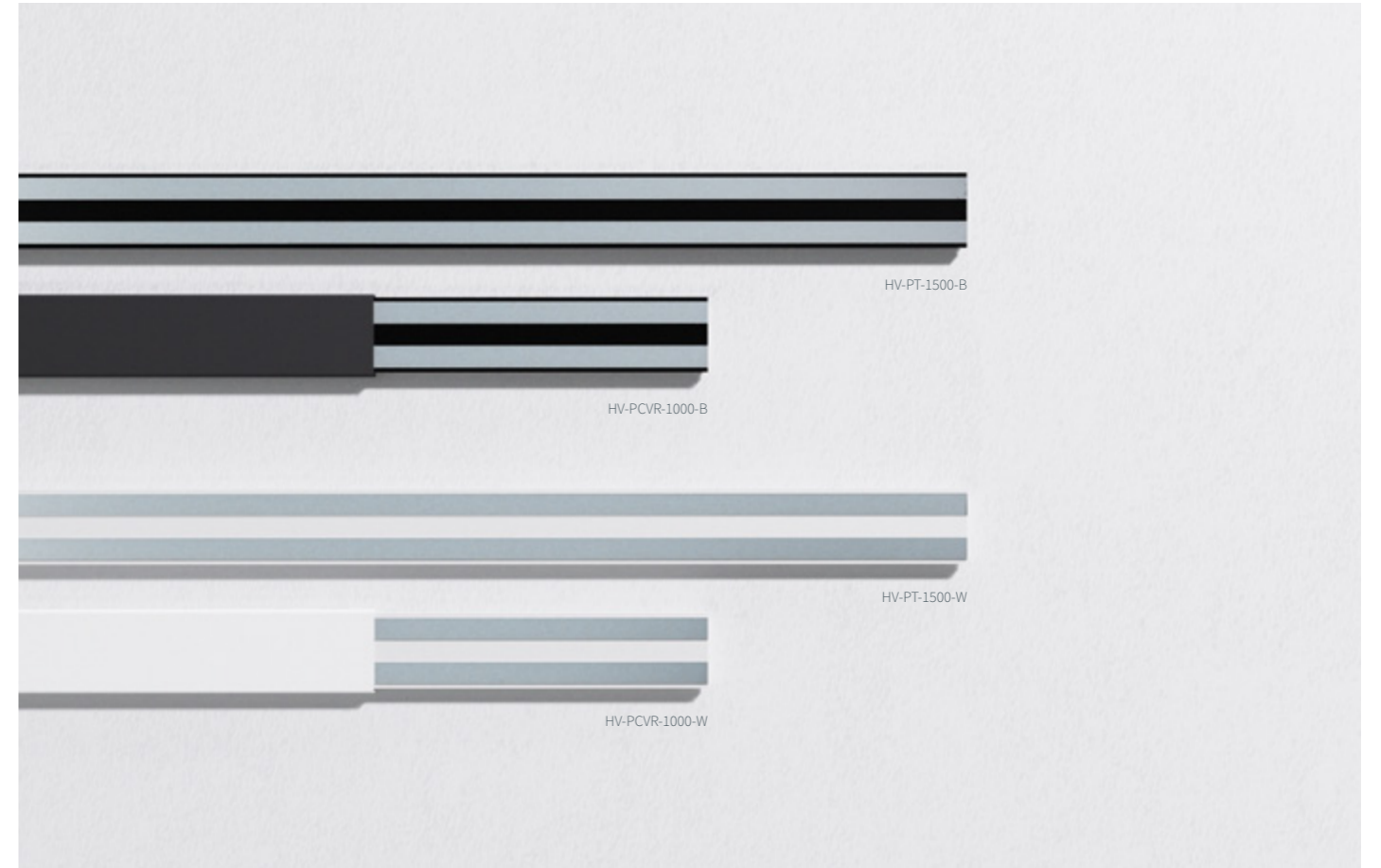

# Konnekt Twist

## Why specify Konnekt Twist

Konnekt Twist is a low-voltage power delivery system that provides a flexible, reliable way of integrating LED lighting and digital enhancements into shelving displays. Konnekt Twist is engineered to operate using secure twist-lock connectors to ensure that luminaires deliver flawless, consistent illumination across any products on display. It can be supplied with both rebated and surface-mounted power tracks to blend seamlessly into the back panels of merchandising systems.

## Key features



Custom design service



Cost-effective installation



Quick turnaround times



Reconfigurable



Retro Fit



Various fixing methods



Recess mount



Surface mount

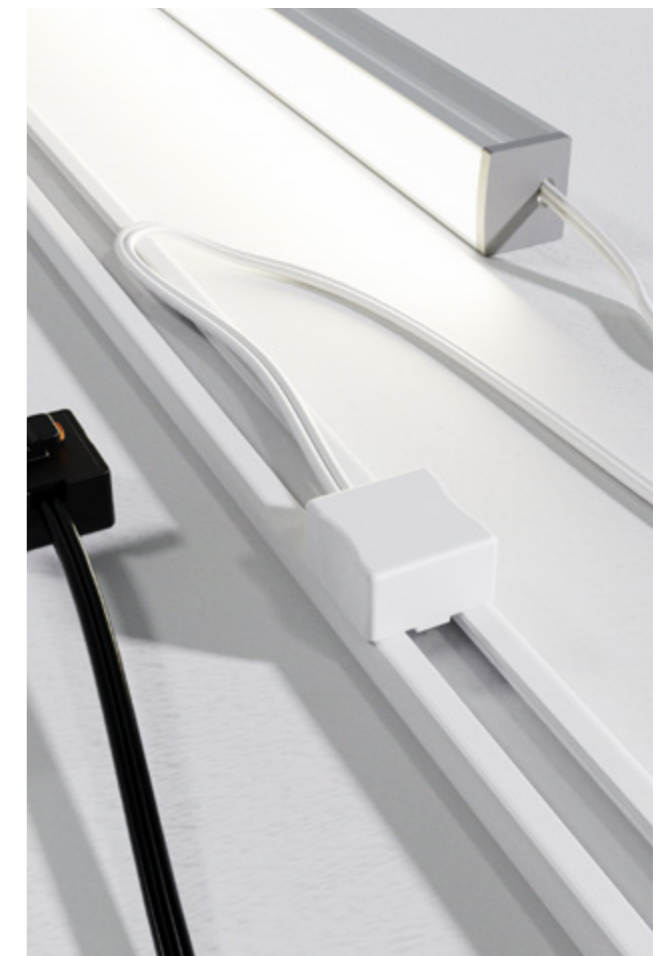

## Track details

Konnekt **Twist recess-mount** features a slim-line power track made from extruded ABS plastic with integrated copper busbar tracks with an 10-amp rating. It is supplied with push fit ABS end caps. The housing can be bonded or mechanically fixed into a multitude of substrates.

Konnekt **Twist surface-mounted** features a slim-line power track made from extruded ABS plastic with integrated copper busbar tracks with an 10-amp rating. It is supplied with push fit ABS end caps. The housing can be bonded or mechanically fixed onto a multitude of substrates.

Rated Voltage	Rated Current (Track)	Rated Current (Connector Power Feed) TWST-PF	Rated Current (Connector Take off) TWST-PTO	Max Continuous Track Length (mm)
12/24V	10AMP	8AMP	2AMP	1500

**Twist power track - TWST-PTS**  
Surface-mount - available in black & white

**Twist power track - TWST-PTR**  
Recess-mount - available in black & white

**Twist power Feed - TWST-PF**  
Available in black and white

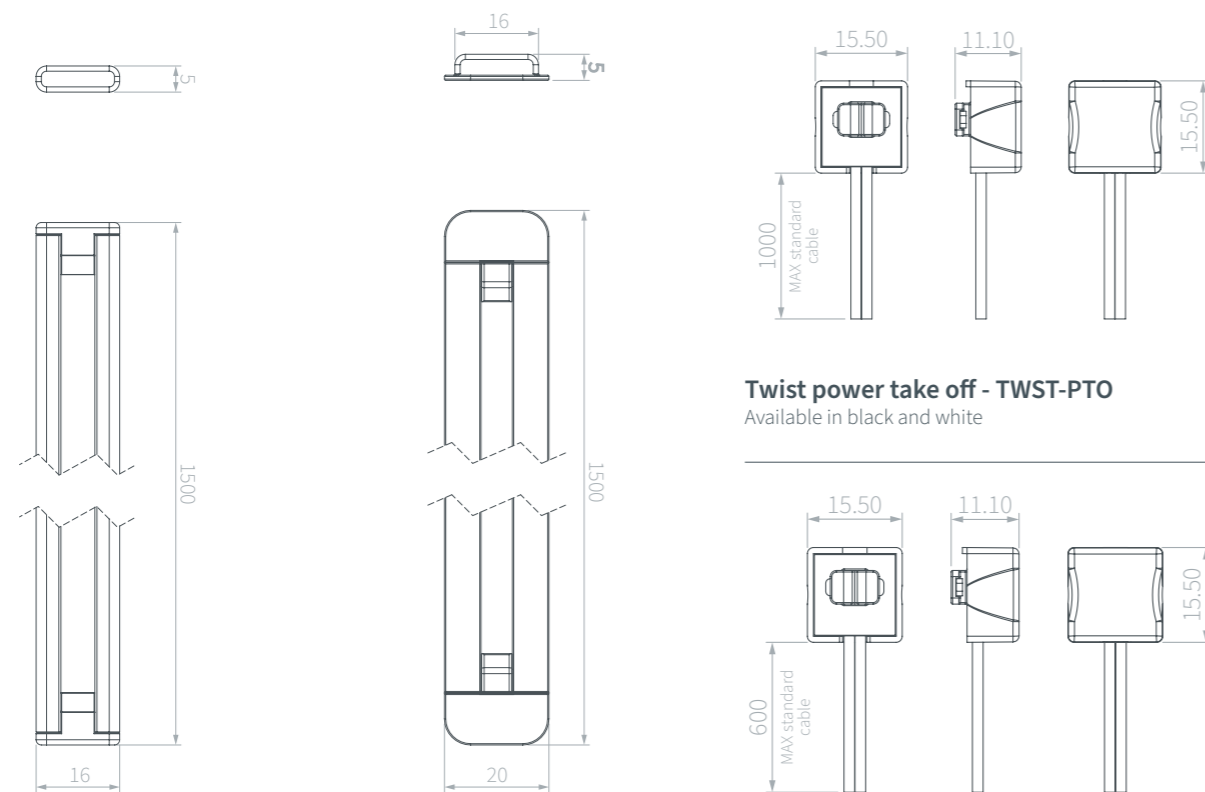

**Twist power take off - TWST-PTO**  
Available in black and white

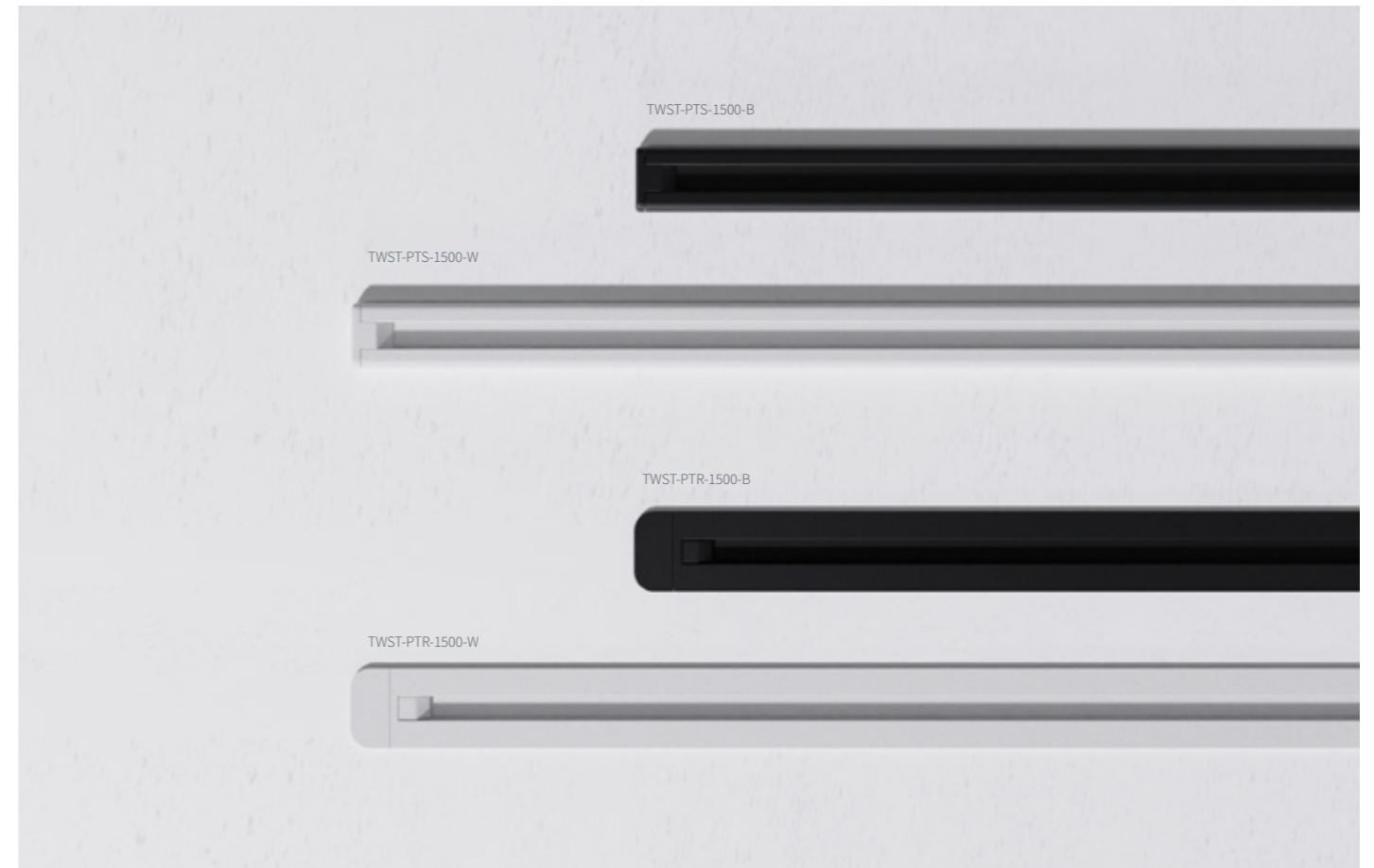



# Powering options

## Lightbars

Slimline LED luminaires for retail and exhibition display systems, designed with effective illumination and ease of installation in mind.

Linear luminaires are integral to Unibox's retail and exhibition display systems, providing the integrated lighting that illuminates products and display stands.

Designed in a range of slimline aluminium profiles specifically made to effectively dissipate heat, Unibox linear luminaires can be customised to suit the product on display, from colour temperature to secondary optics to manipulate the light output.

## Lightboxes

Combining specially created aluminium profiles and range of graphic options - including removable tension fabric graphics and Duratrans quality photographic prints - our edge-lit, side-lit and backlit frames are designed to deliver maximum impact.

Our illuminated displays & graphics can be single or double-sided, freestanding, wall mounted, integrated, or ceiling hung, and are manufactured to custom dimensions and shapes. Helping to maintain brand consistency, our illuminated graphics can also be powder coated, plated, and custom-finished (including wood/stone/graphic finishes directly to the aluminium - contact us for more info) to your precise requirements. With in-house technical design and manufacturing facilities, we're the UK's leading supplier of illuminated graphics.

Key design considerations - For Lightboxes Powered by Konnekt

- Size limitations 150w max. (get in touch for more details)
- Various depth frames.
- 24v & 12v Options (Voltage must match power supply.)

## LED signage

Unibox are specialists in LED lighting, which when combined with our expertise in graphic display, creates some truly eye-catching LED signage solutions. Utilising our in-house manufacturing skills, we provide two different signage options, that are designed to perfectly match your (or your clients) branding.

Neonist is our modern alternative to neon, created using LED illumination and advanced manufacturing techniques which result in high impact signs without the complications (or risks!) that neon is infamous for.

Kontour, our latest LED signage innovation, utilises laser-cut acrylic made custom to your design or font, mounted within almost any housing or display. Kontour benefits from advanced LED illumination, with a custom-coloured edge lit panel.

## Light panels

Light panels are core to Unibox's lighting and graphic display solutions, providing a slimline method of illumination with consistent lighting that can be combined with Unibox LED Lightboxes and multiple other products.

A bespoke, high-quality LED light engine illuminates a dot-matrix patterned light guide plate, produced on our in-house laser-etching machine. The pattern, algorithmically calculated by panel size, creates an even distribution of light across the panel.

## Digital screens

Digital screens can be incorporated into shelving systems using power delivery systems to create a visually dynamic displays that are optimised to capture the attention of passers-by. They enable branded messages, product information and video content to be shown directly alongside physical merchandise without requiring complex networks of unsightly cables.

## 5V charging

Voltage converters can be connected to power delivery systems to facilitate the charging of a wide range of electrical devices such as phones and tablets. Integrating charging capabilities directly into retail display units means there is no need for unsightly extension cables or additional mains access points.

For more information or literature about powering options.

**Please contact Unibox directly by emailing [sales@unibox.co.uk](mailto:sales@unibox.co.uk) or phoning 0161 655 2100).**

## Get In Touch

+44(0)161 655 2100  
info@unibox.co.uk  
www.unibox.co.uk

### HQ:

Greenside Way, Middleton, Manchester M24 1SW

